

# ***A Practical Guide to 'Free Energy' Devices***

Part PatD38: Last updated: 12th March 2010

Author: Patrick J. Kelly

This patent application covers a device which is claimed to have a substantially greater output power than the input power required to run it and it has no moving parts.

**Patent application WO2009065210 (A1)**

**28th May 2009**

**Inventor: Richard Willis**

## **ELECTRICAL GENERATOR**

### **ABSTRACT**

An electrical generator comprising an induction coil with a first magnet positioned adjacent to the first end of the induction coil so as to be in the electromagnetic influence of the induction coil when it is energised, and for creating a magnetic field around at least the first end of the induction coil. There is also a second magnet positioned near the second end of the induction coil so as to be in the electromagnetic field of the induction coil when the induction coil is energised, and for creating a magnetic field around at least the second end of the induction coil. A power input circuit powers the induction coil. A timer is placed in the power input circuit in order to create electrical pulses and controlling their timing. A power output circuit receives power from the induction coil.

### **FIELD OF THE INVENTION**

The present invention relates to an electrical power generator, and more particularly to an "over-unity" electrical power generator.

### **BACKGROUND OF THE INVENTION**

Electricity is conventionally generated in a number of ways, including fossil fuel powered electromechanical generators, coal powered electromechanical generators, water-flow powered electromechanical generators, nuclear reactor type generators, and so on. In each case, there are a number of disadvantages associated with these methods, especially inefficiency and also the scarcity of a power source.

Recently, magnetic generators have been developed which produce electrical power from the magnetic field of the Earth. Basically, an input magnetic field is quickly switched on and off, or alternatively more than one input magnetic field is selectively switched on and off, on an alternating basis, to influence a larger magnetic field in an electromagnetic apparatus that is selectively connected to an electrical power output circuit. A resulting electrical power is produced in the power output circuit.

There are even magnetic generator circuits which produce more electrical power than that which is applied to the circuit. While this seems to contradict the laws of physics, it does not, otherwise, such magnetic generator circuits would not work. These magnetic generator circuits work, on the basic principle that the space-time continuum is very energetic, including energy fields such as the Earth's magnetic field.

It should be understood that electric fields and magnetic fields do not have an independent existence. A purely electromagnetic field in one coordinate system can appear as a mixture of electric and magnetic fields in another coordinate system. In other words, a magnetic field can at least partially turn into an electric field, or vice versa.

It is also well known that a system which is far from equilibrium in its energy exchange with its environment can steadily and freely receive environmental energy and dissipate it in external loads. Such a system, can have a Coefficient of Performance ("COP") greater than 1. For a COP greater than 1, an electrical power system must take some, or all of its input energy, from its active external environment. In other words, the system must be open to receive and convert energy from its external environment, as opposed to merely converting energy from one form to another.

The US Patent 6,362,718 issued on 26th March 2002 to Patrick et al., discloses an electromagnetic generator without moving parts. This electromagnetic generator includes a permanent magnet mounted within a rectangular ring-shaped magnetic core having a magnetic path to one side of the permanent magnet and a second magnetic path to the other side of the permanent magnet. A first input coil and a first output coil extend around portions of the first magnetic path, with the first input coil being at least partially positioned between the permanent magnet and the first output coil. A second input coil and a second output coil extend around portions of the second magnetic path, with the second input coil being at least partially positioned between the permanent magnet and the second output coil. The input coils are alternatively pulsed by a switching and control circuit and provide induced current pulses in the output coils. Driving electrical current through each of the input coils reduces a level of flux from the permanent magnet within the magnetic path around which the input coil extends.

In an alternative embodiment of the Patrick et al electromagnetic generator, the magnetic core includes circular spaced-apart plates, with posts and permanent magnets extending in an alternating fashion between the plates. An output coil extends around each of these posts. Input coils extending around portions of the plates are pulsed to cause the induction of current within the output coils.

The apparent problems with the electric magnetic generator is disclosed in US Patent 6,362,718 seem to be twofold. First, it is more expensive to produce than necessary as it has four coils. Secondly, while it apparently achieves a Coefficient of Performance of more than 3.0, a much greater Coefficient of Performance is readily achievable. This is believed to be due to the specific physical configuration of the magnetic paths.

It is an object of the present invention to provide an electrical generator having a Coefficient of Performance significantly greater than 1.

## **SUMMARY OF THE INVENTION**

In accordance with one aspect of the present invention there is disclosed a novel electrical generator comprising an induction coil. There is a first magnet positioned beside the first end of the induction coil so as to be in the electro-magnetic field of the induction coil when the induction coil is energised, and for creating a magnetic field around at least the first end of the induction coil. There is also a second magnet positioned near the second end of the induction coil so as to be in the electro-magnetic field of the induction coil when the induction coil is energised, and for creating a magnetic field around at least the second end of the induction coil. A power input circuit provides power to the induction coil. A timing device is placed in the input power circuit in order to create electrical pulses and for controlling the timing of those electrical pulses being passed to the induction coil. A power output circuit receives power from the induction coil.

Other advantages, features and characteristics of the present invention, as well as methods of operation and functions of the related elements of the structure, and the combination of parts and economies of manufacture, will become more apparent upon consideration of the following detailed description and the appended claims with reference to the accompanying drawings which are described here:

## **BRIEF DESCRIPTION OF THE DRAWINGS**

The novel features which are believed to be characteristic of the electrical generator according to the present invention, as to its structure, organisation, use and method of operation, together with it's further objectives and advantages, will be better understood from the following drawings in which a preferred embodiment of the invention will now be illustrated by way of example. It is expressly understood, however, that the drawings are for the purpose of illustration and description only, and are not intended as a definition of the limits of the invention. In the accompanying drawings:

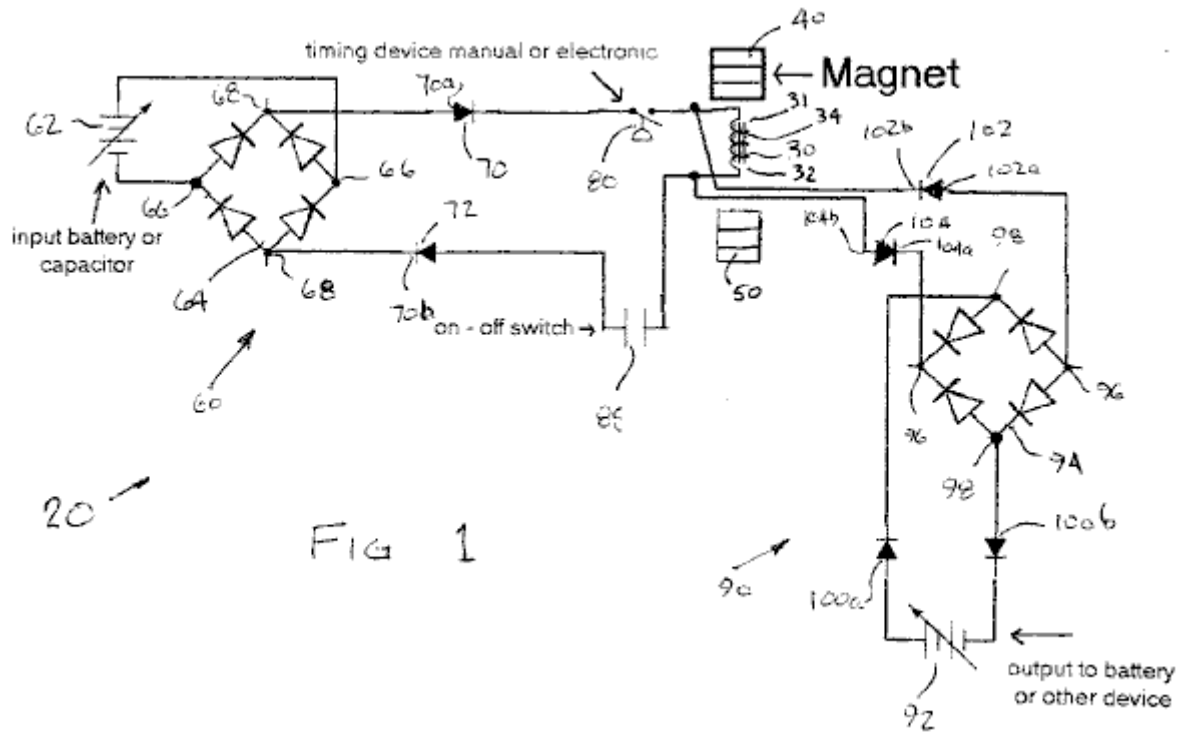

FIG 1

Fig.1 is an electrical schematic of the first preferred embodiment of the electrical generator.

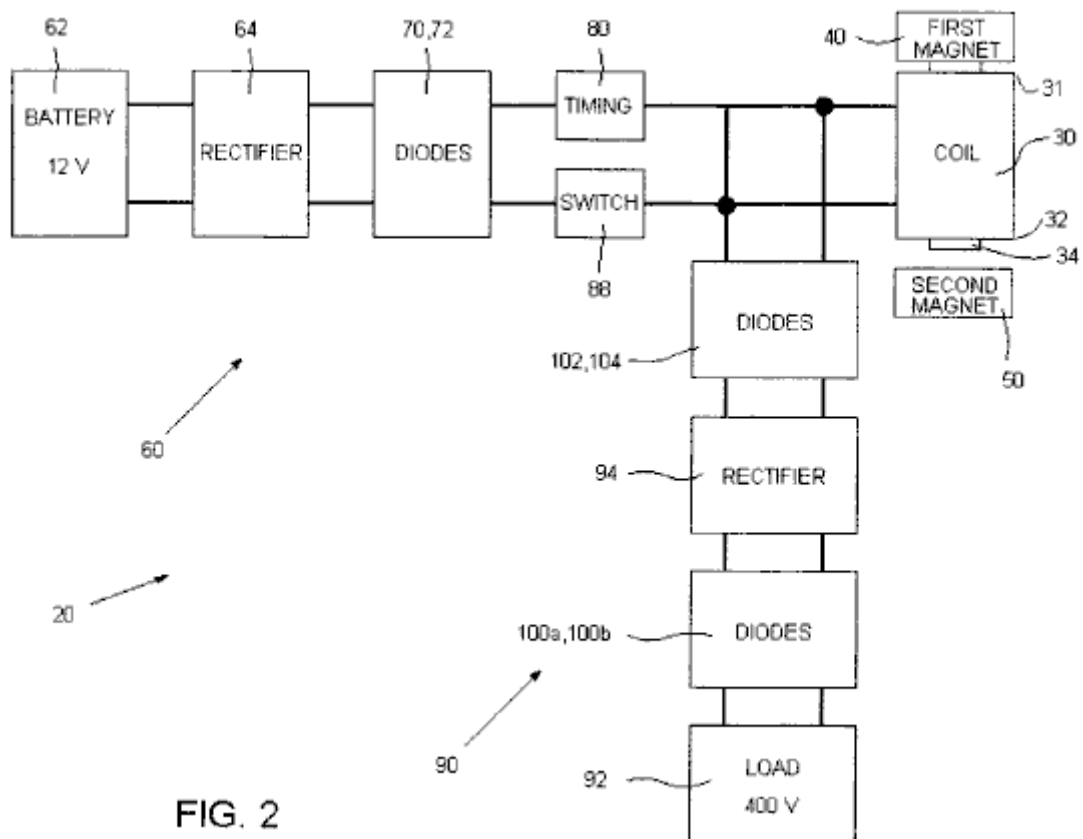

FIG. 2

Fig.2 is a block diagram schematic of the first preferred embodiment of the electrical generator of Fig.1.

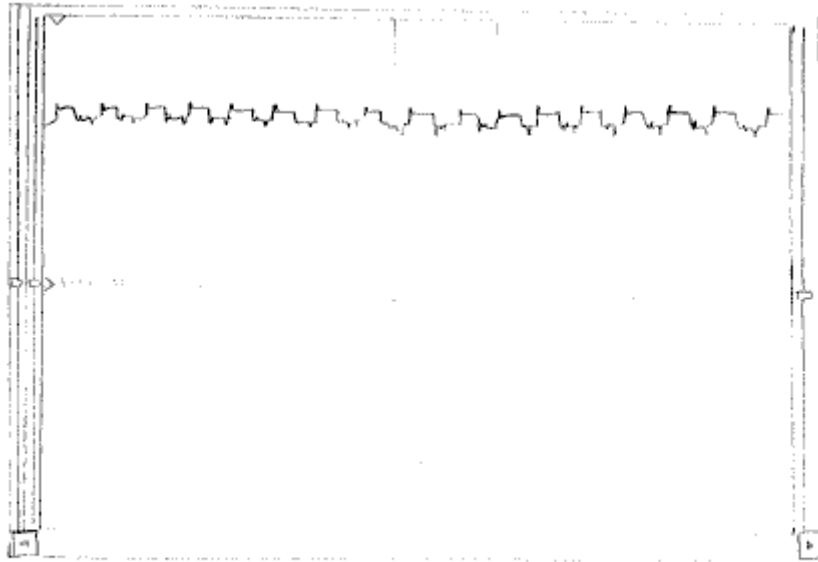

FIG. 3

**Fig.3** is an oscilloscope waveform taken at the input power circuit after the timing mechanism.

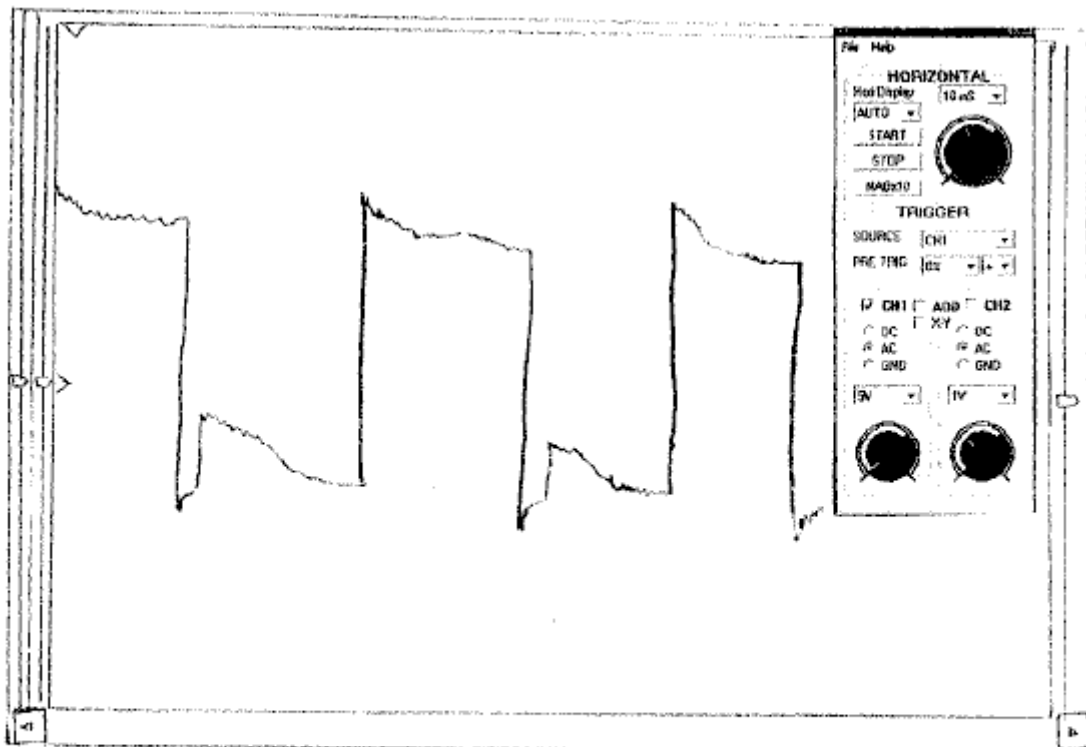

FIG. 4

**Fig.4** is an oscilloscope waveform taken at the output power circuit before the first set of diodes immediately after the coil.

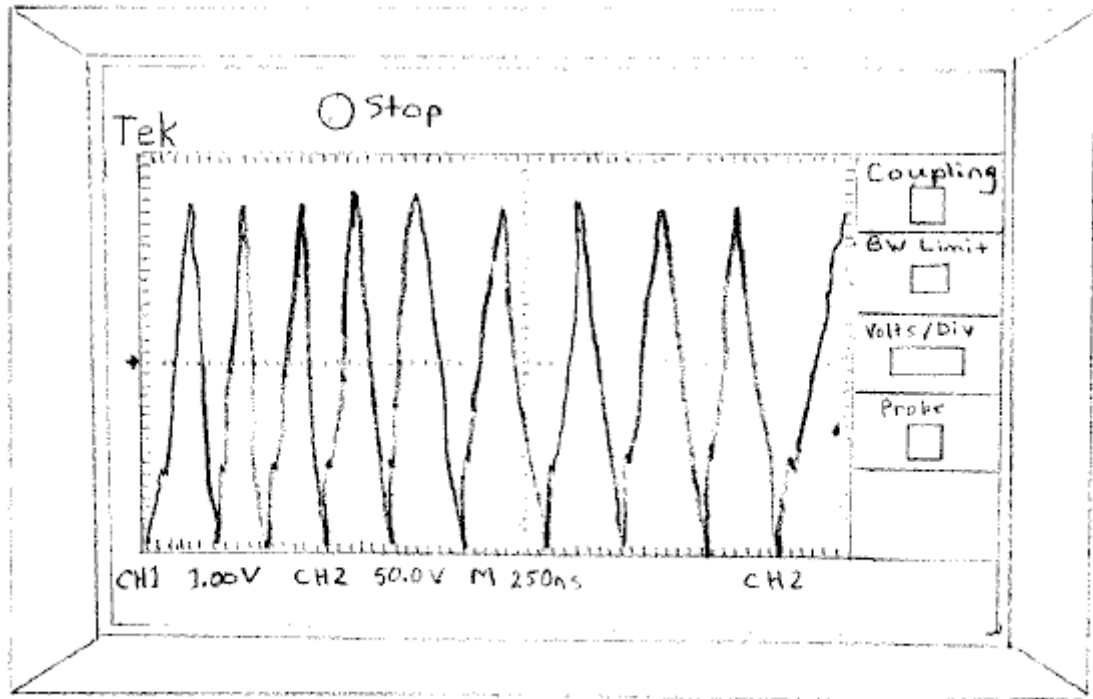

FIG. 5

Fig.5 is an oscilloscope waveform taken at the output power circuit at the load; and,

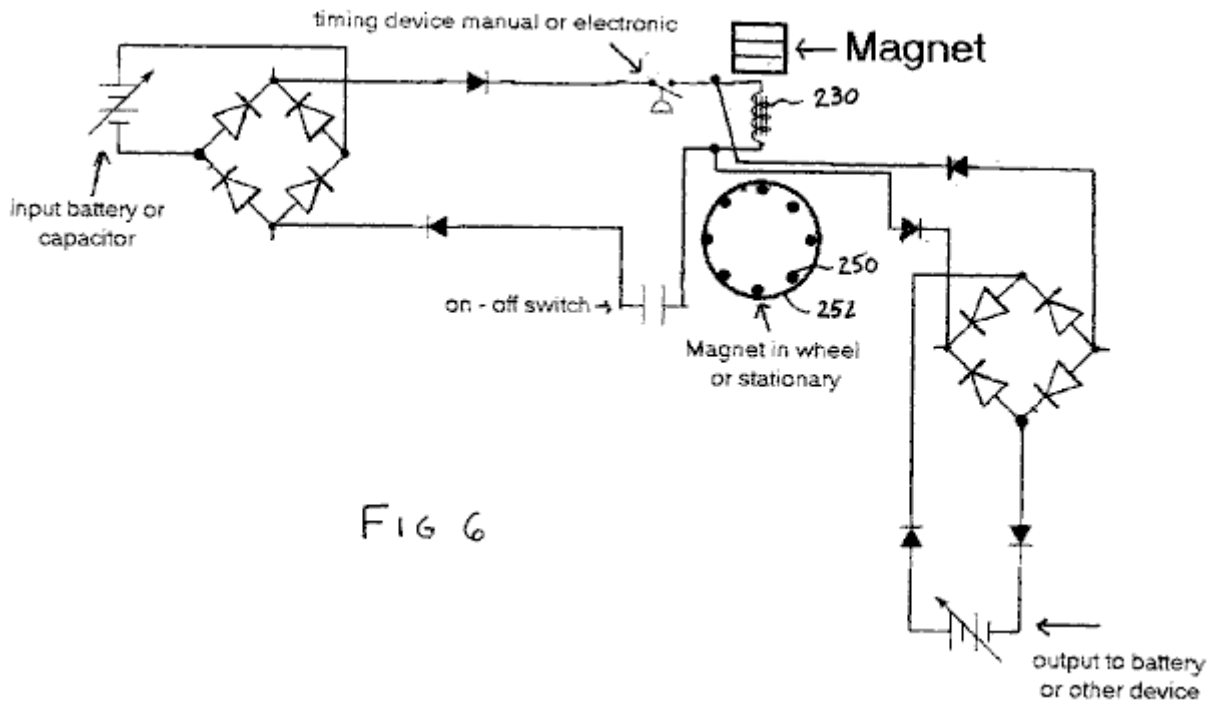

FIG 6

Fig.6 is an electrical schematic of the second preferred embodiment of the electrical generator

### DETAILED DESCRIPTION OF THE PREFERRED EMBODIMENTS

Referring to Fig.1 through Fig.6 of the drawings, it will be noted that Fig.1 through Fig.5 illustrate a first preferred embodiment of the electrical generator of the present invention, and Fig.6 illustrates a second preferred

embodiment of the electrical generator of the present invention.

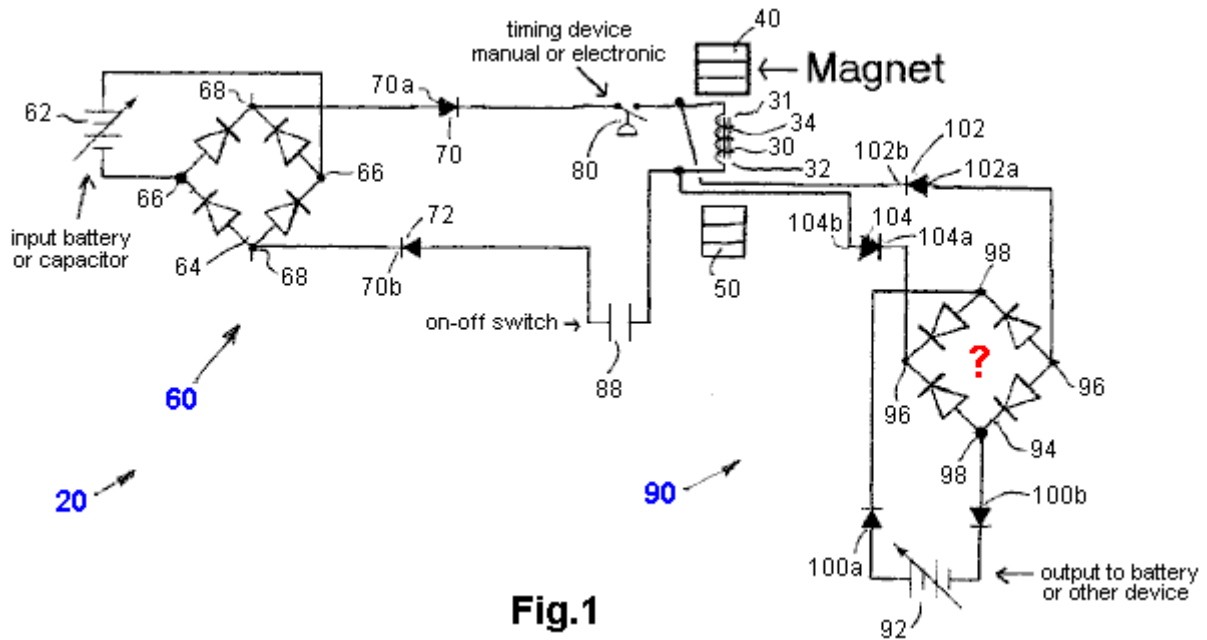

**Fig.1**

Reference will now be made to **Fig.1** through **Fig.5**, which show a first preferred embodiment of the electrical generator of the present invention, as indicated by general reference numeral **20**. The electrical generator **20** comprises an induction coil **30** having a first end **31** and a second end **32**. The induction coil **30** preferably includes a core **34** which is made from any suitable type of material, such as ferrite, mumetal, permalloy, cobalt, any non-permeable metal material, or any other suitable type of material. The coil **30** is wound with copper wire which can be a single size or multiple sizes depending on the size of the ferrite core **34**.

There is a first magnet **40** positioned adjacent to the induction coil **30**, preferably at the first end **31** so as to be within the electromagnetic field of the induction coil **30** when the induction coil **30** is energised. The first magnet **40** is a permanent magnet which has its North pole facing the first end **31** of the induction coil **30**. In the first preferred embodiment, the first magnet **40** is stationary with respect to the induction coil **30**, and even more preferably is in contact with, or is even secured to, the first end **31** of the induction coil **30**. The size of the coil and the copper wire used to wind the coil also depend on the size of the first magnet **40**. The first magnet **40** is there to create a magnetic field around at least the first end **31** of the first magnet **30**.

There is also a second magnet **50** positioned adjacent to the induction coil **30**, preferably at the second end **32** of the induction coil **30** but at a distance of about 1.0 cm or so from the coil core **34** but within the electromagnetic field of the induction coil **30** when the induction coil **30** is energised. The gap between the second end **32** of the induction coil **30** and the second magnet **50** can be an air gap or can be a vacuum.

The second magnet **50** is a permanent magnet which has its North pole facing the second end **32** of the induction coil **30**. In the first preferred embodiment, the second magnet **50** is stationary with respect to the induction coil **30**. The size of the coil and the copper wire used to wind it also depends on the size of the second magnet **50**. The second magnet **50** is there in order to create a magnetic field around at least the second end **32** of the induction coil **30**.

As can be seen in **Fig.1**, the first magnet **40** is positioned so its North pole is facing the first end **31** of the induction coil and its South pole is facing away from the first end **31** of the induction coil **30**. The first end **31** of the induction coil **30** creates a South magnetic field when it is energised. In this manner, the North pole of the first magnet **40** and the South pole of the first end **31** of the induction coil attract each other.

Similarly, but oppositely, the second magnet **50** is positioned so that its North pole is facing the second end **32** of the induction coil and its South pole is facing away from the second end **32** of the induction coil **30**. The second end **32** of the induction coil **30** creates a North magnetic field when the induction coil **30** is energised. In this manner, the North pole of the second magnet **50** and the North pole of the second end **32** of the induction coil repel each other.

A power input circuit section, as indicated by the general reference numeral **60**, is for providing power to the induction coil and is comprised of a source of electrical power **62**. In the first preferred embodiment, as illustrated, the input source of electrical power **62** comprises a DC power source, specifically a battery **62**, but additionally or alternatively may comprise a capacitor (not shown). The source of electrical power can range from less than 1.0

volt to more than 1,000,000 volts, and can range from less than 1.0 amp to more than 1 million amps. Alternatively, it is contemplated that the input source of electrical power could be an AC power source (not shown).

An input rectifier **64** which is preferably, but not necessarily, a full-wave rectifier **64**, has an input **66** electrically connected to the source of electrical power **62** and also has an output **68**. A first diode **70** is connected at its positive end **70a** to one terminal **68a** of the output **68** of the rectifier **62**. A second diode **72** is connected at its negative end **72a** to the other terminal **68b** of the output **68** of the rectifier **62**.

There is also a timing mechanism **80** in the input power circuit section **60**, which as shown, is electrically connected in series with the first diode **70**. This timing mechanism both creates electrical pulses and controls the timing of those electrical pulses which are fed to the induction coil **30**. The pulses are basically saw-tooth waveforms, as can be seen in **Fig.3**.

In the first preferred embodiment, the timing device **80** is a manual timer in the form of a set of "points" from the ignition system of a vehicle, as they can withstand high voltage and high current levels. Alternatively, it is contemplated that the timing mechanism could be an electronic timing circuit. It is also contemplated that a TGBT unit from a MIG welder could be used as the basis of the timing device **80**. It has been found that a timing device which provides a physical break in its "off" configuration works well as stray currents cannot backtrack through the circuit at that time. The timing mechanism can be of any suitable design so long as it can respond to the placement of the magnets **50** in the rotor **52** in the second preferred embodiment shown in **Fig.6**.

When the device is in use, the magnetic fields created by the first magnet **40** and the second magnet **50** in conjunction with the coil **30**, are each somewhat mushroom shaped, and oscillate back and forth, with respect to their size, in a manner corresponding to the timing of the electrical pulses from the power input circuit **60**, as controlled by the timing mechanism **80**.

The power input circuit **60** has an on/off switch **88** to allow disconnection of the power feed to the induction coil **30**. The on/off switch **88** may alternatively be located in any other suitable place in the power input circuit **60**.

A power output circuit section, indicated by the general reference numeral **90**, is for receiving power from the induction coil and comprises an electrical load **92**, which, in the first preferred embodiment is a battery **92**, but may additionally or alternatively comprise a capacitor (not shown), or any other suitable electrical load device.

The power output circuit portion **90** also has an output rectifier **94** having an input **96** an output **98** electrically connected to the electrical load **92** via a pair of forward biased diodes **100a**, **100b** which prevent the electrical load **92** from powering the induction coil **30**. A first diode **102** is electrically connected at its positive end **102a** to one terminal **94a** of the input of the rectifier **94** and is electrically connected at its negative end **102b** to one end of the induction coil **30**. A second diode **104** is connected at its negative end **104a** to the other terminal **94b** of the input of the rectifier **94** and is electrically connected at its positive end **104b** to the other end of the induction coil **30**. The output of the coil, taken before the diodes **102,104** is shown in **Fig.4**.

Note: It is highly likely that there is a clerical error in **Fig.1** because as it is drawn the bridge input is point **98** and not **96** as stated. If this is the case, then the two diode bridges are identical and the output section should be drawn like this:

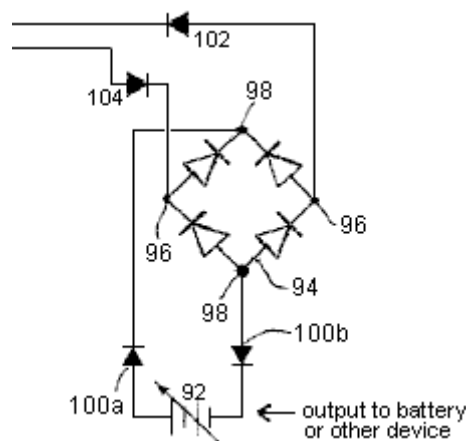

although it is by no means obvious why diodes 102 and 104 are needed as their function would appear to be provided by the output bridge diodes.

The output to the electrical load **92** of the power output circuit **90** can range from less than 1 volt to more than 1,000,000 volts, and can range from less than one amp to more than 1 million amps. As can be seen in **Fig.5**, the output to the electrical load **92** comprises generally spike-shaped pulses which have both negative and positive components.

As can be readily seen in **Fig.1** and **Fig.2**, the input power circuit **60** is electrically connected in parallel with the induction coil **30** and the output power circuit portion **90** is electrically connected in parallel with the induction coil **30**.

The various diodes and rectifiers in the electrical generator **20** can be of any suitable voltage from about 12 volts to over 1,000,000 volts, and can have slow recovery or fast recovery, as desired. Further, the various diodes and rectifiers may be configured in other suitable formats. There also may be additional capacitors added into the power output circuit adjacent to the electrical load **92** in order to increase the output power before discharge.

It has been found that setting the timing to six hundred pulses per minute (10 Hz) provides a waveform in the power output circuit portion **90** that comprises generally spike-shaped pulses with a period of about 20 nanoseconds. It is believed that the flux of the power pulses that are input into the induction coil **30** is quickly shifting the magnetic field back and forth in the induction coil **30**, which is akin to the flux of the power pulses creating its own echo. The various electromagnetic oscillations in the coil provide a much higher frequency in the power output circuit **90** than in the power input circuit portion **60**.

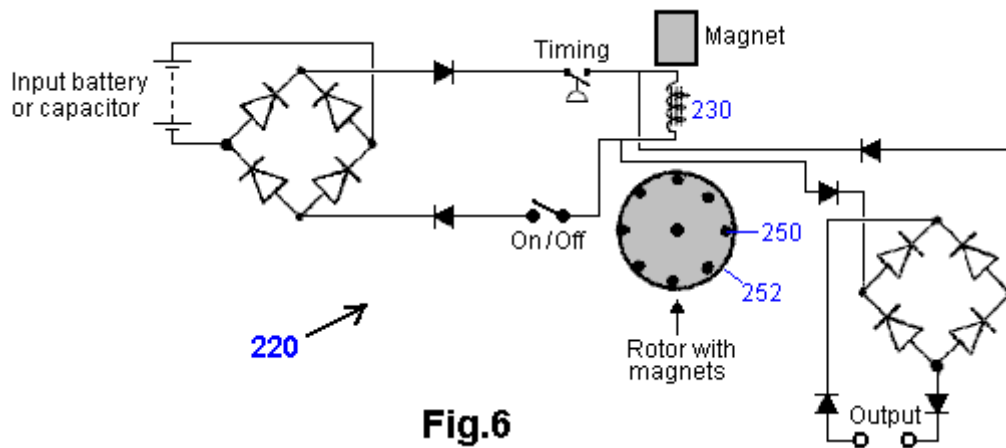

**Fig.6**

Reference will now be made to **Fig.6**, which shows a second preferred embodiment of the electrical generator of the present invention, as indicated by general reference numeral **220**. The second preferred embodiment electrical generator is similar to the first preferred embodiment electrical generator **20** except that the second magnet comprises several moving magnets **250**, typically eight permanent magnets **250**. These magnets are mounted on a wheel **252**, which is free to rotate. Ideally, these magnets are mounted in an identical way to each other on the rotor disc **252**. If desired, there can be any suitable number of magnets mounted in the rotor. Accordingly, at least one rotor magnet **250** will be within the electromagnetic field of the induction coil **230** when the coil is energised. The rotor magnets can be of any suitable strength and any suitable type of magnet, and they may be mounted on the rotator by any suitable means, such as a suitable adhesive, or moulded into the disc if the rotor is made of plastic. In practice, the rotor disc is driven round by the magnetic field of the induction coil when it is energised. It is also possible for the first magnet to a rotor magnet in the same manner as described for the second magnet **250**.

As can be understood from the above description and from the accompanying drawings, the present invention provides an electrical generator having a Coefficient of Performance greater than 1.0. and more specifically, an electrical generator which has a Coefficient of Performance significantly greater than 1.0. An electrical generator having a Coefficient of Performance significantly greater than 1.0 is at present, unknown in the prior art.

Other variations of the above principles will be apparent to those who are knowledgeable in the field of the invention, and such variations are considered to be within the scope of the present invention. Further, other modifications and alterations may be used in the design and manufacture of the electrical generator of the present invention without departing from the spirit and scope of the following claims:

## **CLAIMS**

**1.** An electrical generator comprising:



an induction coil having a first end and a second end;

a first magnet positioned adjacent said first end of said induction coil so as to be in the electromagnetic field of said induction coil when said induction coil is energized, and for creating a magnetic field around at least said first end of said induction coil,

a second magnet positioned adjacent said second end of said induction coil so as to be in the electro-magnetic field of said induction coil when said induction coil is energized, and for creating a magnetic field around at least said second end of said induction coil;

a power input circuit portion for providing power to said induction coil;

a limiting means in said power input circuit portion for creating electrical pulses and controlling the timing of said electrical pulses to said induction coil; and,

a power output circuit portion for receiving power from said induction coil.

2. The electrical generator of claim 1 , wherein said first magnet is stationary with respect to said induction coil.
3. The electrical generator of claim 2, wherein said first magnet comprises a permanent magnet.
4. The electrical generator of claim 2, wherein said induction coil includes a core.
5. The electrical generator of claim 4, wherein said first magnet is in contact with said core.
6. The electrical generator of claim 4, wherein said core is made from a material chosen from the group of ferrite, mumetal, permalloy, and cobalt.
7. The electrical generator of claim 4, wherein said core is made from a non-permeable metal material.
8. The electrical generator of claim 3, wherein said second magnet is stationary with respect to said induction coil.
9. The electrical generator of claim 8, wherein said second magnet comprises a permanent magnet.
10. The electrical generator of claim 1, wherein said second magnet comprises at least one movable magnet.
11. The electrical generator of claim 10. wherein said at least one movable magnet is mounted on a rotor.
12. The electrical generator of claim 11 , wherein said at least one movable magnet comprises a plurality of magnets mounted on said rotor.
13. The electrical generator of claim 1, wherein said power input circuit portion comprises a source of electrical power, a input rectifier having an input electrically connected to said source of electrical power and an output, a first diode connected at its positive end to one terminal of said input rectifier, a second diode connected at its negative end to the other terminal of said input rectifier.
14. The electrical generator of claim 13, wherein said timing means is electrically connected in series with said first diode.
15. The electrical generator of claim 14, wherein said power output circuit portion comprising an electrical load, an output rectifier having an output electrically connected to said electrical load via a pair of forward biased diodes and an input, a first diode connected at its negative end to one terminal of said output rectifier, a second diode connected at its positive end to the other terminal of said output rectifier.
16. The electrical generator of claim 15, wherein said input power circuit portion is electrically connected in parallel with said induction coil and said output power circuit portion is electrically connected in parallel with said induction coil.
17. The electrical generator of claim 1, wherein said input source of electrical power comprises a DC power source.
18. The electrical generator of claim 17, wherein said DC power source comprises a battery.
19. The electrical generator of claim 17, wherein said DC power source comprises a capacitor.
20. The electrical generator of claim 1 , wherein said input source of electrical power comprises an AC power source.
21. The electrical generator of claim 1 where the input rectifier is a Wheatstone bridge rectifier.

- 22.** The electrical generator of claim 1 , wherein said timing means comprises an electronic timing circuit.
- 23.** The electrical generator of claim 1 , wherein said timing means comprises a manual timer.
- 24.** The electrical generator of claim 1 , wherein said first magnet comprises a permanent magnet.
- 25.** (Appears to have been omitted from the archived copy)
- 26.** The electrical generator of claim 12, wherein said plurality of movable magnets are each mounted similarly one to another on said rotatable wheel.
- 27.** The electrical generator of claim 1 , wherein said electrical load comprises a battery.
- 28.** The electrical generator of claim 1 , further comprising an on/off switch electrically connected in said power input circuit portion.